

MAN

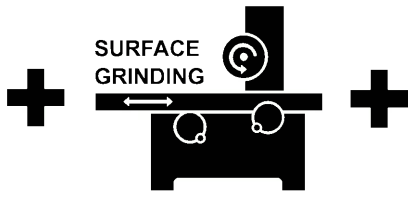

MACHINE



PUNCH FORMER



MODIFY PUNCH SHAPE

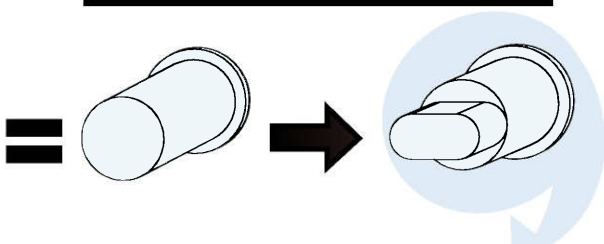

Used for forming deformed punches



High precision
High durability
Low cost
Japan design
& quality



PF-001

PUNCH FORMER



MOVIE

PUNCH FORMER PF-001

FEATURE



High precision & high durability

High precision and high durability are achieved by adopting Cross roller bearing

MADE BY IKO NIPPON THOMPSON



Cost reduction

No need for an expensive cylindrical grinder, just a surface grinder and PF-001(Our PUNCH FORMER)

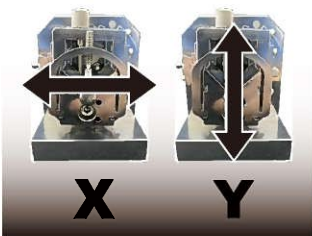

Can be processed into a wide variety of shapes

By adjusting the X and Y axis ,eccentricity can be made, and it is possible to process not only perfect circles but also various shapes



SPECIFICATION

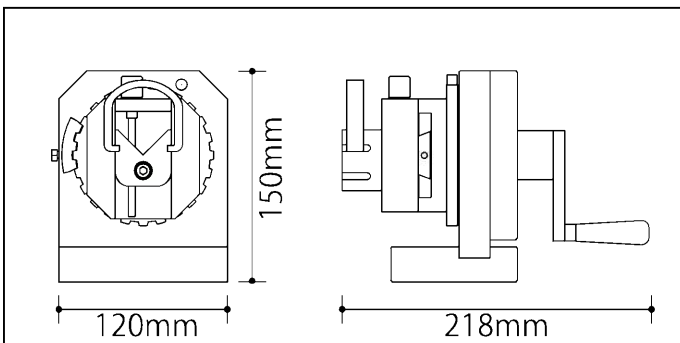

| | |
|--------------------------------------|----------------------------------|
| Type | PF-001 |
| Product Dimension | 120x218x150 |
| X/Y axis adjustable V block movement | X 17mm / Y35mm |
| Workpiece size | φ 10 to φ 30 Round Objects |
| Center Height | 92mm |
| Indexing angle | With 15 degree indexing function |
| Tick marks | Position |
| Weight | 9kg |
| Molding accuracy | 0.005mm |

Specification is subject to change without notice.

OTHER PRODUCTS



POLISHING MACHINE



WIRE CUT VISE

OUR COMPANY



SANKO SEIMITSU Co.,Ltd.
Wakayama Japan



PT.YSPI
Indonesia

General agent in INDONESIA



PT.YSPI (Yogyua Sanko presisi)

Jl. Industri Sel. IV, Pasirsari, Cikarang Sel.,
Kabupaten Bekasi, Jawa Barat 17530

PERSON IN CHARGE : YUDITHA yuditha@yspi.co.id
DINA dina@yspi.co.id

General agent in THAILAND



AOISEIKI(THAILAND)Co.,Ltd.

41/99 15 Buiding, Moo 6, soi Phun Charoen, Debaratana Rd. Km.16.5,
T. Bangchalong, A. Bangplee, Samutprakarn 10540

TEL:027637712 FAX:027637712

ผู้รับผิดชอบภาษาไทย : TSUTSUI as.tsutsui@aoiseiki.co.jp
ผู้รับผิดชอบภาษาไทย : PAIRIN pairin@aoiseiki.co.jp

MAN

MACHINE

PUNCH FORMER

多様な形状に高精度で加工可能

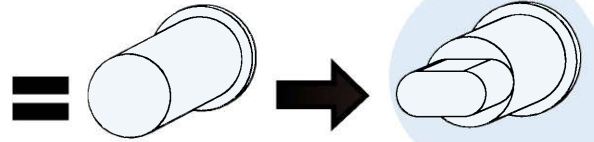
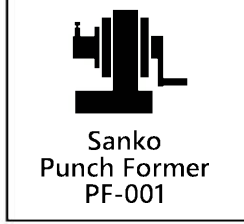
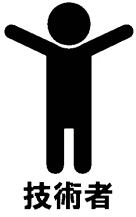

マルモノパンチのリサイズ加工
異形状パンチへの成形加工が
簡単確実高精度に可能



高精度

High precision

高耐久

High durability

高品質

Japan design
& quality



PF-001

**PUNCH
FORMER**



MOVIE

特徴



高品質 & 高耐久

IKO NIPPON THOMPSON 社製クロスローラーベアリングを採用する事により
高精度・高耐久を実現

MADE BY IKO NIPPON THOMPSON



コスト削減

平面研削盤とパンチフォーマー (PF-001) さえあれば高価な円筒研削盤は
必要なし

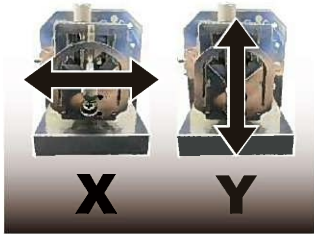

多種多様な形状への加工が可能

X軸及びY軸を調整する事により偏心させる事ができ、真円に限らず多様な
形状に加工する事が可能



仕様

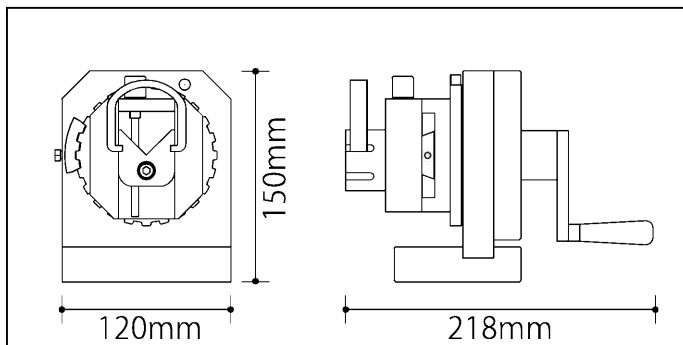

| | |
|--------------|-----------------------|
| 型 式 | PF-001 |
| 製品サイズ | 120x218x150 |
| X/Y 軸調整可能範囲 | X 方向 17mm / Y 方向 35mm |
| 加工可能サイズ (直径) | φ10 から φ30 円筒形状 |
| 中心高さ | 92mm |
| 割り出し角度 | 15° ピッチ |
| 目盛り | あり |
| 重 量 | 9kg |
| 成形精度 | 0.005mm |

予告なく仕様変更される場合がございます。

その他取り扱い製品



拠点情報



お問い合わせ先

製造販売元

Sanko Seimitsu

株式会社 三晃精密

和歌山県橋本市高野口町小田 565-1

TEL : 0736-44-20365 FAX : 0736-43-2062

E-mail : info@sankoseimitsu.co.jp

インドネシア拠点

YS

PT.YSPI (Yogya Sanko Presisi Indonesia)

Jl. Industri Sel. IV, Pasirsari, Cikarang Sel.,
Kabupaten Bekasi, Jawa Barat 17530

PERSON IN CHARGE : YUDITHA yuditha@yspi.co.id
DINA dina@yspi.co.id

タイ販売総代理店

AOISEIKI

AOISEIKI(THAILAND)Co.,Ltd.

41/99 15 Buiding Moo 6 soi Phun Charoen Debaratana Rd.Km.16.5,
T.Bangchalong,A.Bangplee Samutprakarn 10540

TEL:027637712 FAX:027637712

タイ販売総代理店: TSUTSUI as.tsutsui@aoiseiki.co.jp
タイ販売総代理店: PAIRIN pairin@aoiseiki.co.jp